



HYDROBAR SPRINT 565 S2 BARFEED

AUTOMATIC MAGAZINE BAR FEEDER FOR
FIXED HEADSTOCK LATHES

Diameter range: 1/4" to 2 - 1/2" (5 mm - 65 mm)

Bar length: 40" to 12'6"



YOUR "ONE-STOP-SHOP"
FOR MACHINE-TOOL PERIPHERALS



Robust Design

The Hydrobar Sprint 565 S2 offers a compact robust design with a heavy duty frame to support high performance with minimal vibration for improved productivity. The Hydrobar Sprint 565 S2 is the only barfeeder capable of hydrodynamic or hydrostatic operation. The hydrostatic front stabilizer, permits increased RPM, enhanced productivity, surface finish and extended tool life for fixed headstock machines.



State of The Art Controls

Combined with a Servo Motor and latest PLC technology, fully automatic Hydrobar Sprint 565 S2 provides "State of the Art" bar feeding solutions.

Added connectivity (Ethernet, USB) for interface communication with advanced CNC controls.

User Friendly Hand Held Remote Control Station

The user friendly Touch Screen HMI with prompting menu screens ensures the interaction between the bar feeder and the lathe, and therefore the production process can run safely and efficiently.



Parts Library

For added flexibility and faster production changeovers, the "Parts Library" allows the user to store specific parameter configurations that are unique to a machining program. After all the parameters have been entered the first time, the configuration is saved as a unique number that will be associated to a specific machining program.

The "Parts Library" is a standard benefit and can be used with a Standard or Ethernet interface.

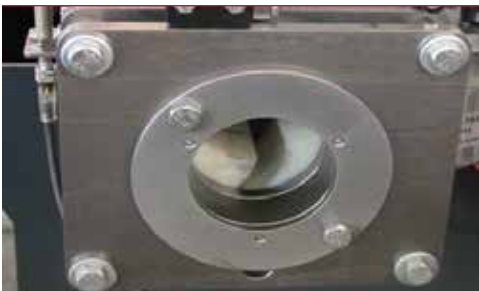

Precise Performance with Minimal Vibration

When running round bar stock at optimum RPMs, it is vital to minimize bar vibration for production to operate efficiently.

The Hydrobar Sprint 565 S2 features a compact design with all steel machined parts assembled on a heavy duty frame. Coupled with the heavy duty frame design and depending on production needs, the Hydrobar Sprint 565 S2 offers a hydrostatic or hydrodynamic guiding support with or without remnant retract or with an automatic front rest to guarantee optimum RPMs without vibration for the entire range of diameters.

The automatic front stabilizer prevents troublesome bar vibrations from transferring to the machine cut area. And, it adjusts automatically to the bar and pusher diameters simply by inputting the bar stock diameter into the control menu.



Maximizing Productivity

Reducing downtime during changeover increases productivity which contributes to achieving your customer's demands.

Complete diameter changeover for the Hydrobar Sprint 565 S2 can be achieved in less than eight minutes.

The hydrodynamic and hydrostatic bearing elements are easily accessible, which makes handling them quite simple.

The operator can change the guiding element manually in a matter of seconds with no tool required. With this kind of changeover speed, you can quickly and competitively meet customer demands.

Just install the appropriate guiding elements and follow the prompting remote control menu. After the parameters have been entered in the control menu, the Hydrobar Sprint 565 S2 automatically adjusts.



Minimize Loading Time

Standard remnant ejection through the chuck of the lathe minimizes loading time and increases productivity. Running unattended operation through a weekend allows you to stay ahead of the competition.

The bar stock remnant disposal option allows you to choose whether the new loaded bar should push the remnant through the lathe's chuck or the remnant should be ejected into a storage drawer at the rear of the magazine bar loader. Front or rear load available for optimum utilization of floor space when loading magazine tray.



Safe Loading System Providing Unattended Operation

Operators lifting heavy barstock while loading to the working height can be hazardous and decreases production time.

The Hydrobar Sprint 565 S2 offers a standard chain loading system safely holding bars for unattended operation eliminating the need to lift heavy bars to the center height of the lathe for reloading. Additional barstock can be easily and safely loaded onto the chain loading system without production interruption.

Providing longer run times, the Hydrobar Sprint 565 S2 can run unattended holding nine bars.

An optional 25" wide horizontal floor mounted storage provides additional storage capacity which allows the system to run unattended for longer periods of time.



HYDROBAR SPRINT 565 S2 BARFEED

TECHNICAL SPECIFICATIONS

Capacity		
Diameter	mm	5 - 65
Bar Length (40" to 12'6")	mm	1000 to 3800
Loading System		Chain Load Rack
Loading Capacity		9 Bars
Loading Side		Left Front Load
Remnant Retract (2.44")	mm	62 max without bar prep bar diameter exceeding 62 requires bar prep
Remnant Length (4.25" to 17.7")	mm	110 to 450
Shipping Weight	lbs	3,080

Applications		
Type of Headstock		Fixed
Headstock Synchronization		PLC / Servo Motor
Controls		Hand Held, Touch Screen with Parts Library (500 Parts)
Zaxis Retract	mm	500

Changeovers		
Partial changeover	min	2 or less within the range of guide channel
Complete changeover	min	8 or Less

Driving Systems and Bar Support		
Motor		Servo
Drive		Notched Belt
Guiding Channel		Hydrostatic Bearings
ISO 100 oil	gal	14

Options		
Hex bar applications		
25" Horizontal floor mounting storage rack		
Left rear load		

Barstock Straightness Specifications and Performance

For optimum rotational performance speeds, bar stock straightness needs to be .020" per 3.25 feet, non accumulative. Bar stock out of this tolerance will not run at optimum RPM. Other factors such as material type (brass, copper, bronze and other malleable materials), clamping efficiency of the machine workholding, alignment of the bar feed, oil type, bar preparation and spindle liners will affect optimum RPM capability of the system.

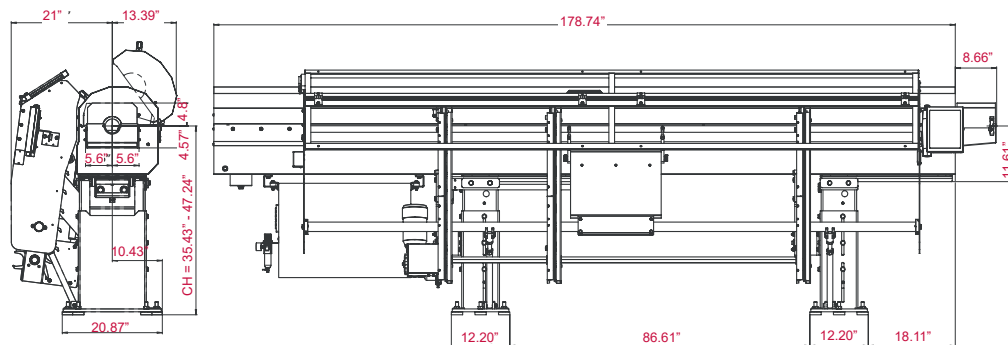

YOUR "ONE-STOP-SHOP" FOR MACHINE-TOOL PERIPHERALS

LNS provides a full range of barfeeders, chip conveyors, coolant management systems, air filtration systems, and workholding systems that is second to none on the market. We are known in the industry for the solid experience we have gained over several decades in an exceptionally wide range of applications, our excellent customer service, and our technical support. This support is ensured by highly qualified technicians who are available throughout North America.



LNS America
4621 East Tech Drive
Cincinnati, Ohio 45245

513-528-5674
Sales@LNS-america.com
www.LNS-america.com



LNS America, Inc.
ISO 9001-10013185
LNS Turbo
ISO 9001-10000276
Facilities covered by this mark have been evaluated to international quality assurance standards by UL DQS Inc.