



FOX WM OIL / COOLANT MIST COLLECTORS

FOX WM SERIES:
2500 • 5000 • 7500



YOUR "ONE-STOP-SHOP"
FOR MACHINE-TOOL PERIPHERALS

Specifications subject to change without notice



The Fox WM series represents the ideal solution for the filtration of oil mist for large machining centers, connecting multiple machine tools or for when large air flow rates are required.

Designed with the same level of high quality engineering and reliability of the smaller Fox WS series, the WM unit can completely eliminate mist, aerosol and smoke typical of wet machining processes exceeding OSHA and NIOSH guidelines for mist concentration for industrial air quality. Fox WM unit is modular in its flow rate and available in 2500, 5000 and 7500 CFM versions.

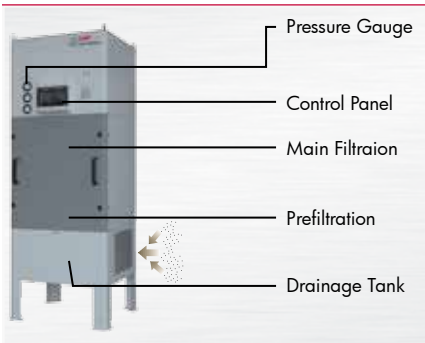

Guaranteed Filtration – Principle of Operation : Two (2) Stages

1st Stage – INITIAL PRE-FILTRATION

Proprietary Multilayered Filtration

Special media with progressive filtration levels that allow the removal of chips and larger particles of oil but provides slow and efficient draining effect.

2nd Stage – MAIN FILTRATION

Proprietary High Surface Area Filtration

Extended filtration area, made of a multi-media arrangement with a filtration level above 99% (measured according to AFNOR NFX44-060) removing the finer particle sizes.

Absolute Filtration (Optional):

Absolute filter HEPA H10 or H13 with efficiency equivalent to 99.95% MPPS according to EN 1822 which completely eliminates aerosols and dry smoke or other particles.



LNS guarantees the output filtration efficiency of our products. Our internal lab can certify the performances of our filters according to the international reference norms. Upon request we can provide a consultancy service in order to assess the results obtained in terms of oil mist residual concentration inside the workshop once the units are installed.

Our proprietary filters have an extra long lifetime and maintenance interval (longer than the average industry standard). This is ensured due to the large filtering surface area and the use of specific types and arrangement of media. Units are mechanically guaranteed for three (3) years and the internal filter set for a minimum of one (1) year.

Options:

- Frequency inverter for reducing electrical consumption
- Remote relay
- Timer
- Custom paint
- LED lights alarm for filters maintenance

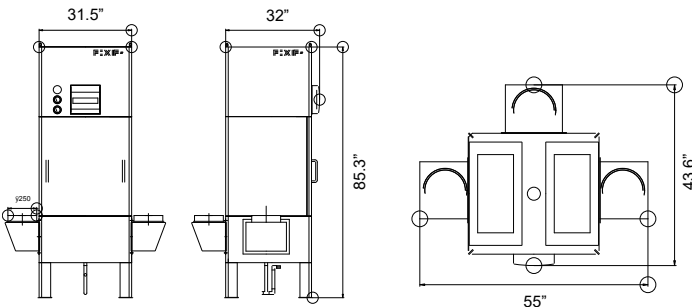

Technical specifications*		60 Hz
Air flow**	[cfm]	2350
Static pressure	[pa]	2300
Motor	[hp]	4.8
Weight	[lb]	620
Sound level	[dB(A)]	80
Suction Inlet [in]	[in]	(3) 13.75 x 10

All units painted in RAL 7035/7016. Information is subject to change without notice
 ** With Hepa filter installed

YOUR "ONE-STOP-SHOP" FOR MACHINE-TOOL PERIPHERALS

LNS provides a full range of barfeeders, chip conveyors, coolant management systems, air filtration systems, and workholding systems that is second to none on the market. We are known in the industry for the solid experience we have gained over several decades in an exceptionally wide range of applications, our excellent customer service, and our technical support. This support is ensured by highly qualified technicians who are available throughout North America.



LNS America
 4621 East Tech Drive
 Cincinnati, Ohio 45245

513-528-5674
 Sales@LNS-america.com
 www.LNS-america.com



LNS America, Inc.
 ISO 9001-10013185
 LNS Turbo
 ISO 9001-10000276
 Facilities covered by this mark have been evaluated to international quality assurance standards by UL DQS Inc.